

GX 270

Horizontal shaft gasoline (petrol) engine



Moteur à essence à arbre de prise de force horizontal

Benzinmotor mit horizontaler Kurbelwelle

Motore a benzina ad albero orizzontale

Bensinmotor med horisontell axel

Benzinmotor met horizontale uitgaande as

GX 270

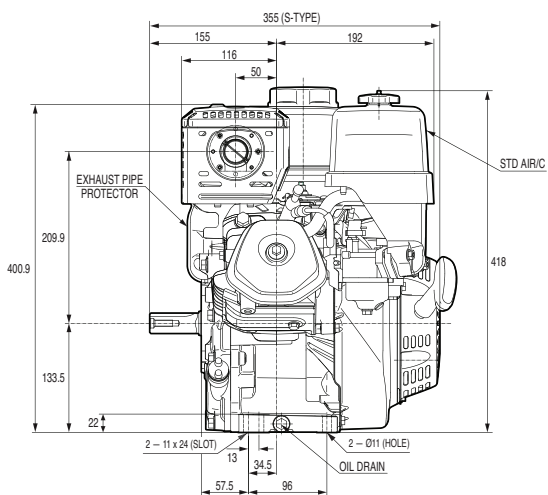
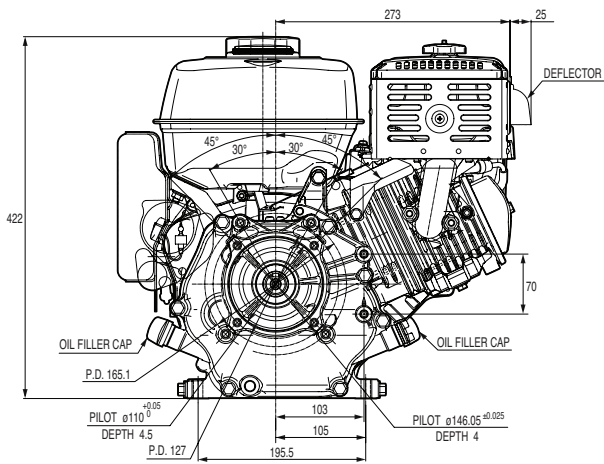
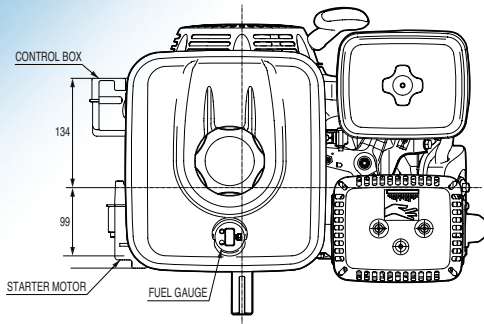
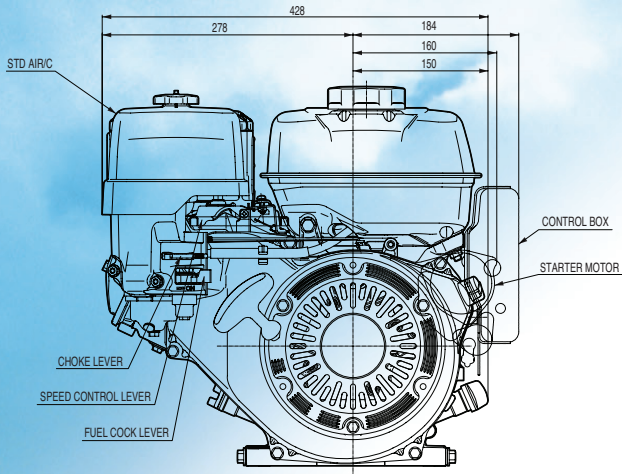

REDUCTION TYPES

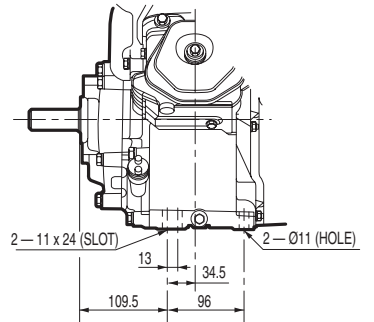
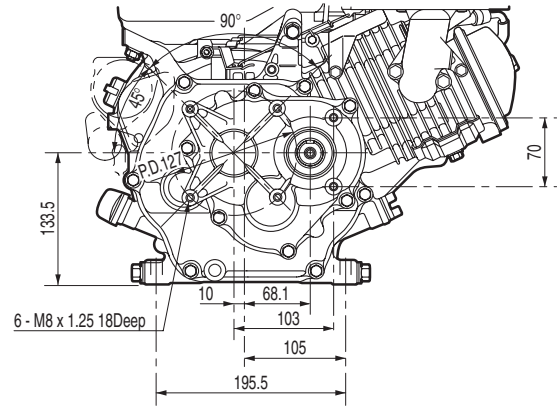

1/2 REDUCTION 1/2 REDUCTION WITH CLUTCH

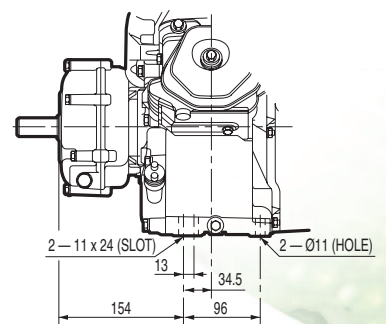
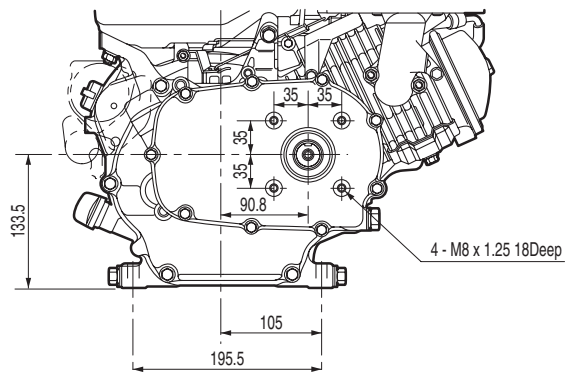

PTO SHAFT DIMENSIONS

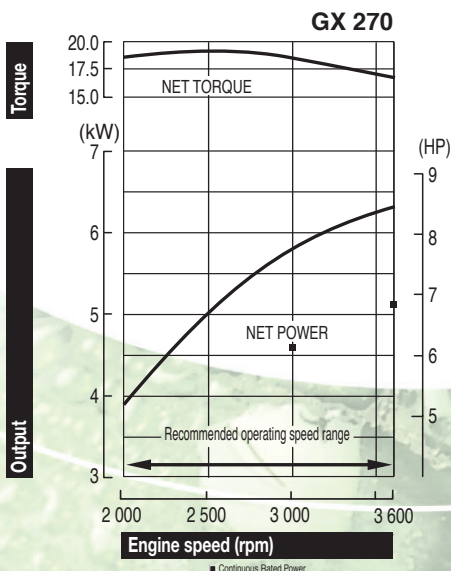
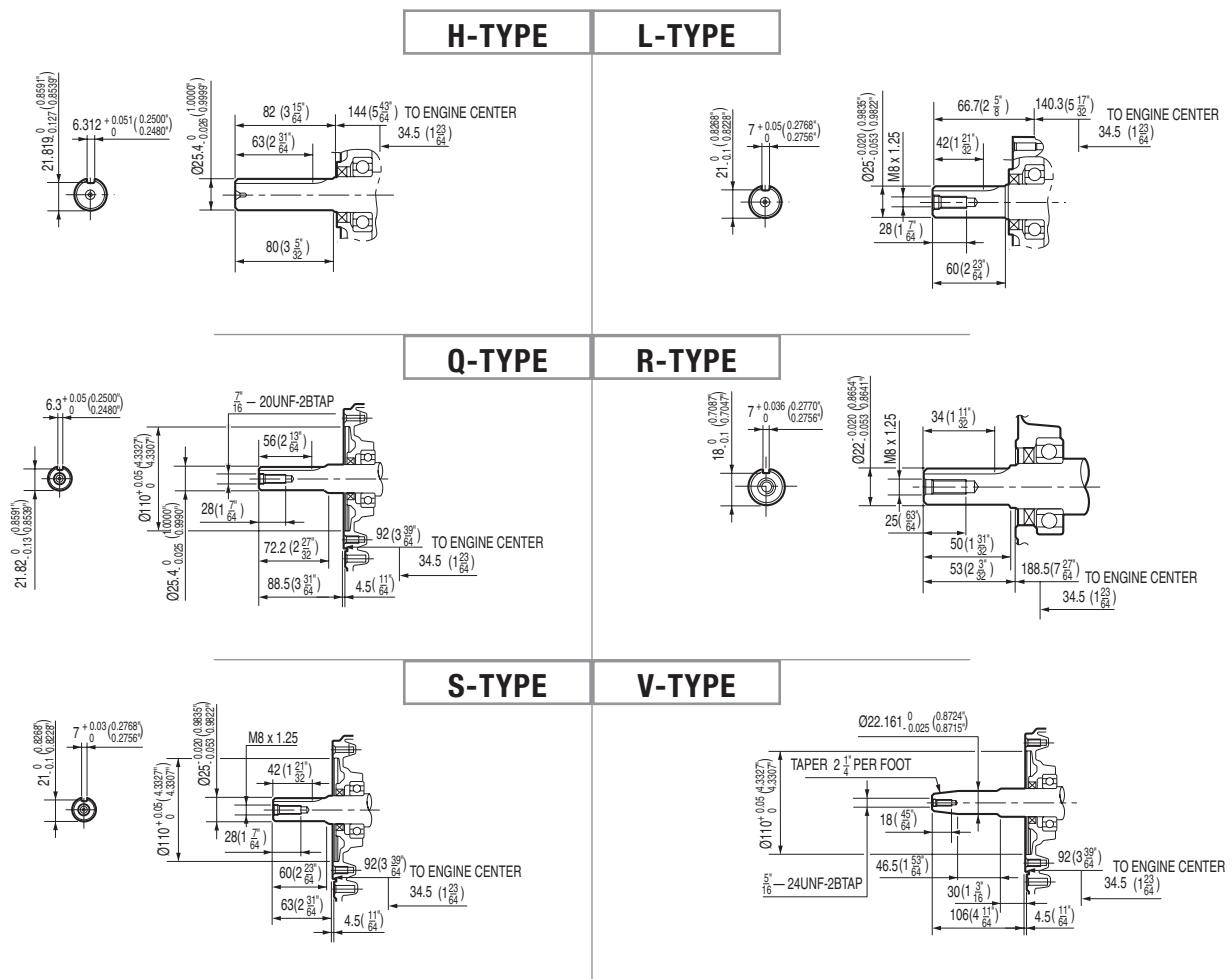

The power rating of the engine indicated in this document is the net power tested on a production engine for the engine model and measured in accordance with SAE J1349 at a specified rpm. Mass production engines may vary from this value. Actual power output for the engine installed in the final machine will vary depending on numerous factors, including the operating speed of the engine in application, environmental conditions, maintenance, and other variables.

La puissance du moteur indiquée dans ce document est une puissance nette obtenue par l'essai d'un moteur de série selon la norme SAE J 1349 à une vitesse de rotation donnée. La puissance d'un autre moteur de production peut être différente de cette valeur indiquée. La puissance réelle d'un moteur installé sur une machine dépendra de différents facteurs comme la vitesse de rotation, les conditions de température, d'humidité, de pression atmosphérique, de maintenance et autres.

Die Leistungsangabe der in diesem Dokument aufgeführten Motoren ist die Netto-Leistung gemäß SAE J1349, getestet bei einer definierten Drehzahl an einem Produktionsmotor. Bei Motoren aus Serienproduktion kann der Wert abweichen. Die Leistungsabgabe in einem Fertigerät weicht, bedingt durch unterschiedliche Faktoren, wie Motordrehzahl in der Applikation, Umwelteinflüsse, Grad der Instandhaltung und andere Einflüsse ab.

La potenza indicata in questo documento, è la potenza netta rilevata su questo modello di motore in fase di produzione, ed è stata misurata secondo la procedura SAE J1349 ad un numero di giri specifico. Nella produzione di massa si possono riscontrare variazioni rispetto a questi valori. La potenza del motore installato nella macchina può dipendere da numerosi fattori, incluso il numero di giri al quale il motore è impiegato, le condizioni ambientali, dal livello di manutenzione ed altre variabili.

De bepaling van het vermogen van de motor, vermeld in dit document, is het netto vermogen getest op een productiemotor en gemeten in overeenstemming met SAE J1349 aan een specifieke t/min. Motoren van massaproductie kunnen van deze waarde variëren. Het werkelijke vermogen van de geïnstalleerde motor in het eindproduct kan afwijken, afhankelijk van talrijke factoren, zoals de operationele snelheid van de motor in een applicatie, omgevingsfactoren, onderhoud en andere variabelen.

Den i detta dokument nämnda motors effekt, är uppmätt i netto effekt. I enlighet med mätmetoden SAE J1349. Massproducerade motorer kan avvika från nämnda värde. Den faktiska effekten för varje motor kan variera beroende på bl a. varvtal, yttre omgivning, underhåll, typ av applikation, mm.

Specifications

| Model GX 270 | |
|---------------------------------|--|
| Engine type | Air cooled 4-stroke OHV petrol engine, 25° inclined cylinder, horizontal shaft, cast iron sleeve |
| Bore x stroke | 77 x 58 mm |
| Displacement | 270 cm ³ |
| Compression ratio | 8.5 : 1 |
| Net power | 6.3 kW (8.4 HP) / 3 600 rpm |
| Cont. rated power | 4.6 kW (6.2 HP) / 3 000 rpm 5.1 kW (6.8 HP) / 3 600 rpm |
| Max. net torque | 19.1 Nm / 1.94 kgfm / 2 500 rpm |
| Ignition system | Digital CDI with variable ignition timing |
| Starting system | Recoil starter (electric start optional) |
| Fuel tank capacity | 5.3 l |
| Fuel cons. at cont. rated power | 2.4 L/hr - 3 600 rpm |
| Engine oil capacity | 1.1 l |
| Dimensions (L x W x H) | 381 x 428 x 422 mm |
| Dry weight | 25,8 kg |

Spezifikationen

| Modell GX 270 | |
|-----------------------------------|--|
| Motortyp | Luftgekühlter 1-Zylinder 4-Takt OHV Benzinmotor, um 25° geneigter Zylinder, horizontale Kurbelwelle, Gußeisen Buchse |
| Bohrung x Hub | 77 x 58 mm |
| Hubraum | 270 cm ³ |
| Verdichtung | 8.5 : 1 |
| Netto-Leistung | 6.3 kW (8.4 HP) / 3 600 min ⁻¹ |
| Max. Dauerleistung | 4.6 kW (6.2 HP) / 3 000 min ⁻¹ 5.1 kW (6.8 HP) / 3 600 min ⁻¹ |
| Max. Netto-Drehmoment | 19.1 Nm / 1.94 kgfm / 2 500 min ⁻¹ |
| Zündsystem | Digitale CDI-Zündung mit variablem Zündzeitpunkt |
| Starter | Zugstarter (Elektrostart Sonderausstattung) |
| Tankinhalt | 5.3 Liter |
| Benzinverbrauch bei Dauerleistung | 2.4 L/h - 3 600 min ⁻¹ |
| Motorölkapazität | 1.1 Liter |
| Maße (L x B x H) | 381 x 428 x 422 mm |
| Trockengewicht | 25,8 kg |

Specificaties

| Model GX 270 | |
|---|--|
| Motortype | Luchtgekoelde 4-takt OHV benzinmotor, 25° hellende cilinder, horizontale uitgaande as, gietijzeren cylinderbus |
| Boring x slag | 77 x 58 mm |
| Cilinderinhoud | 270 cm ³ |
| Compressie | 8.5 : 1 |
| Netto vermogen | 6.3 kW (8.4 HP) / 3 600 t/min |
| Continu nominaal vermogen | 4.6 kW (6.2 HP) / 3 000 t/min 5.1 kW (6.8 HP) / 3 600 t/min |
| Max. netto koppel | 19.1 Nm / 1.94 kgfm / 2 500 t/min |
| Ontsteking | Digitale CDI met variabel ontstekingstijdstip |
| Startsysteem | Repeteerstarter (electrische start optioneel) |
| Tankinhoud | 5.3 Liter |
| Brandstofverbruik aan cont. nominaal vermogen | 2.4 l/u - 3 600 t/min |
| Motoroliecapaciteit | 1.1 Liter |
| Afmetingen (L x B x H) | 381 x 428 x 422 mm |
| Drooggewicht | 25,8 kg |

Spécifications techniques

| Modèle GX 270 | |
|--|---|
| Type du moteur | Moteur à essence monocylindre 4 temps OHV, refroidissement à air, cyl. incliné 25°, arbre de prise de force horizontal, cyl. chemisé en fonte |
| Alésage x course | 77 x 58 mm |
| Cylindrée | 270 cm ³ |
| Taux de compression | 8.5 : 1 |
| Puissance nette | 6.3 kW (8.4 HP) / 3 600 tr/mn |
| Puissance en service continu | 4.6 kW (6.2 HP) / 3 000 tr/mn 5.1 kW (6.8 HP) / 3 600 tr/mn |
| Couple maximum | 19.1 Nm / 1.94 kgfm / 2 500 tr/mn |
| Système d'allumage | CDI numérique avec allumage à avance variable |
| Système de démarrage | Lanceur à rappel (démarreur électrique en option) |
| Cap. du réservoir d'ess. | 5.3 l |
| Consommation de carburant en service continu | 2.4 litre(s)/heure - 3 600 tr/mn |
| Capacité d'huile moteur | 1.1 l |
| Dimensions (L x l x H) | 381 x 428 x 422 mm |
| Poids à sec | 25,8 kg |

Dati tecnici

| Tipo GX 270 | |
|---|---|
| Tipo di motore | Motore monocilindrico OHV ad albero orizzontale, ciclo otto, 4 tempi, cilindro inclinato di 25° raffreddamento ad aria forzata, cilindri in ghisa |
| Alesaggio x corsa | 77 x 58 mm |
| Cilindrata | 270 cm ³ |
| Rapporto di compressione | 8.5 : 1 |
| Potenza netta | 6.3 kW (8.4 HP) / 3 600 giri/min |
| Potenza nominale continua | 4.6 kW (6.2 HP) / 3 000 giri/min 5.1 kW (6.8 HP) / 3 600 giri/min |
| Coppia massima | 19.1 Nm / 1.94 kgfm / 2 500 giri/min |
| Accensione | Digital CDI con anticipo accensione variabile |
| Avviamento | Autoavvolgente (elettrico opzionale) |
| Capacità serbatoio | 5.3 Litri |
| Consumo di combustibile alla potenza continuativa | 2.4 Litri/ora - 3 600 giri/min |
| Capacità coppa olio | 1.1 Litri |
| Dimensioni (Lu x La x A) | 381 x 428 x 422 mm |
| Peso a secco | 25,8 kg |

Specificationer

| Modell GX 270 | |
|--|---|
| Motortyp | Luftkyld 4-takts bensinmotor med överliggande ventiler, 25° lutande cylinder, Horisontal axel, cylinderfoder i gjutjärn |
| Cylinderdiameter x slaglängd | 77 x 58 mm |
| Slagvolym | 270 cm ³ |
| Kompressionsförhållande | 8.5 : 1 |
| Netto effekt | 6.3 kW (8.4 HP) / 3 600 varv per minut |
| Rek. kontinuerlig effekt | 4.6 kW (6.2 HP) / 3 000 varv per minut 5.1 kW (6.8 HP) / 3 600 varv per minut |
| Max. netto vridmoment | 19.1 Nm / 1.94 kgfm / 2 500 varv per minut |
| Tändsystem | Digital CDI med variabel tändning |
| Startsystem | Startapparat (elektrisk start som tillval) |
| Tankvolym | 5.3 Liter |
| Bränsleförbrukning vid kontinuerlig märkeffekt | 2.4 L/tim - 3 600 varv per minut |
| Oljevolym | 1.1 Liter |
| Dimensioner (L x B x H) | 381 x 428 x 422 mm |
| Torrsvikt | 25,8 kg |

All specifications are subject to change without notice. Les caractéristiques techniques peuvent être modifiées à tout moment et sans préavis. Spécifikationerna kan ändras utan föregående meddelande.

Le specifiche sono soggette a cambiamento senza preavviso. Die Spezifikationen können ohne Vorankündigung geändert werden. Die technische specificaties kunnen op elk ogenblik en zonder kennisgeving gewijzigd worden.

HEEC - TS GX 270 - 7809 Feb. 2013 - Printed in Belgium 



Honda Europe NV
EUROPEAN ENGINE CENTER
Langerbruggestraat 104
B-9000 Gent
TEL: + 32 (0)9 250 12 11
FAX: + 32 (0)9 250 14 24

www.honda-engines-eu.com

Honda Engines - France

Honda Motor Europe Ltd Succursale France • Parc d'Activités de Pariest • Allée du 1^{er} Mai, BP 46 • Croissy Beaubourg F-77312 Marne-la-Vallée Cedex 2 • TEL: + 33 (0)1 60 37 30 16 • FAX: + 33 (0)1 60 37 33 66

Honda Engines - Germany

Honda Deutschland Ndl. der HME Ltd. • Hanauer Landstraße 222-224 • D-60314 Frankfurt
TEL: + 49 (0) 69 8309 (0) 365 • FAX: + 49 (0) 69 8309 (0) 128

Honda Engines - Italy

Honda Logistic Centre Italy S.p.A. • Via Strà 153-154 • I-37030 Colognola ai Colli (VR)
TEL: + 39 045 6173341 • FAX: + 39 045 6151270

Honda Engines - Sweden

Honda Nordic • Box 31002 • SE-200 49 Malmö
TEL: + 46 40 38 07 00 • FAX: + 46 40 38 07 05

Honda Engines - United Kingdom

Honda Logistics Centre (UK) Ltd. • Viscount Way, South Marston Park • Swindon SN3 4TN, UK
TEL: + 44 (0)1 455 559429 • FAX: + 44 (0)1 455 559428

Honda Engines - Russia

Representative office of Honda Europe in Russia
Building 1, Pridorozhnaya Street, Sharapovo settlement, Marushkinsky District • 143350 Moscow, Russian Federation
TEL: + 7 (495) 745 2080 • FAX: + 7 (495) 745 2081